

3012176
03/01/11-03-31/03/14

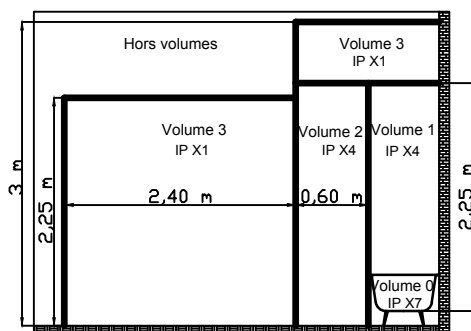
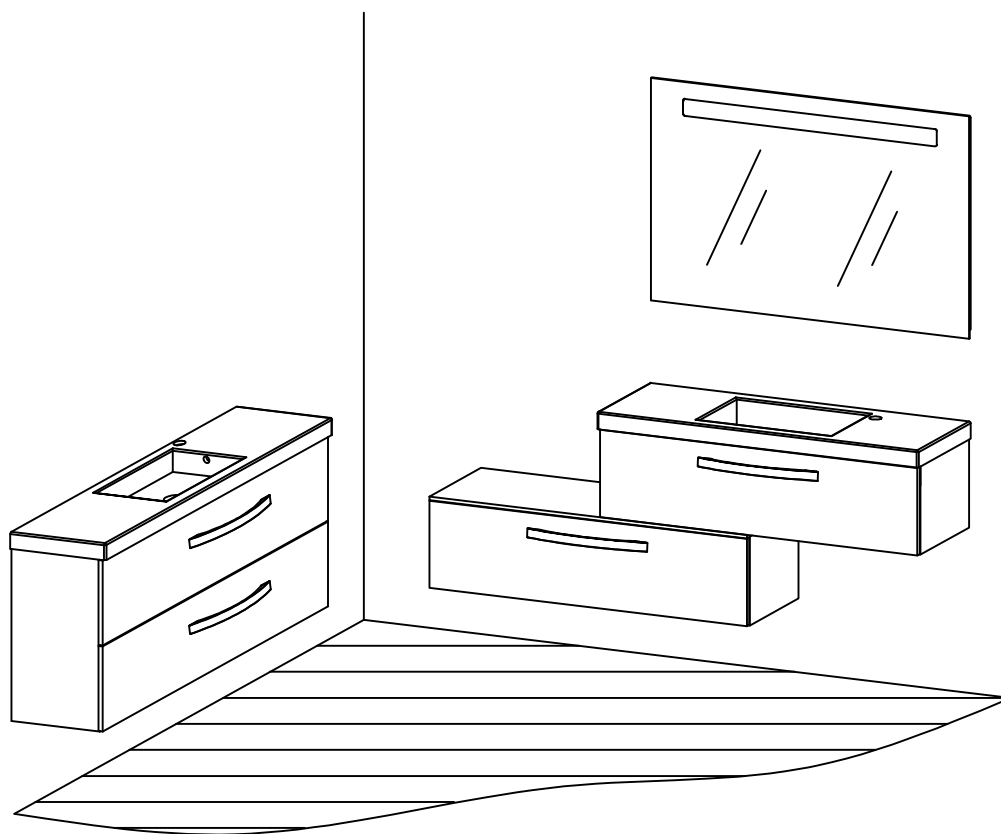

Précaution: couper le courant du circuit concerné ou de l'installation électrique lors du branchement

Cet appareil de classe II peut être installé dans les volumes 2 et 3 de la salle de bains (en aucun cas, il ne peut être installé au dessus de la baignoire ou dans le volume du bac à douche). Si l'appareil est équipé d'un socle 2P+T, celui ci doit impérativement se trouver dans le volume 3 (à plus de 0.60 m de la baignoire ou de la douche).

Si le câble extérieur souple ou le cordon de ce luminaire est endommagé, il doit être remplacé exclusivement par le fabricant, son service de maintenance ou toute personne de qualification équivalente, ceci afin d'éviter tout risque.

Le bloc de jonction n'est pas inclus. L'installation peut exiger l'avis d'une personne qualifiée.



- (F) Cette notice est destinée à faciliter le montage du meuble, elle n'est pas contractuelle.
- (GB) Fitting instructions are intended to ease fitting. They are not subject to contract.
- (D) Unverbindliche Montageanleitung.
- (NL) Deze montageinstructie is gemaakt om de montage van het meubel te vergemakkelijken, zij is niet bindend.
- (SP) Esta nota de instrucciones le ayudará a montar el mueble, no es contractual.
- (I) Le seguenti istruzioni sono destinate a facilitarvi il montaggio del mobile, e sono indicative.
- (P) Esta noticia é destinada a facilitar a montagem do móvel, não é contratual.
- (RUS) Настоящие инструкции помогут вам проще и быстрее собрать мебель. Производителю в любое время может внести изменения в изделие для улучшения качества и усовершенствования дизайна



- (F) Le choix des types de vis et chevilles, ainsi que la méthode de perçage pour les fixations murales sont fonction de la nature et de la qualité du mur et, de ce fait, relèvent de la seule responsabilité du poseur.
- (GB) Since the type of wall determines the fittings necessary for each unit, bolts and screws have not been supplied but left to the responsibility of the installer.
- (D) Die schrauben, dübel und die bohrungen für die montage müs der beschaffenheit der jeweili wandkonstruktion angepasst werden (mauerwerk, siporex, gisplatten usw), die verantwortung eine korrekte befestigung trägt der fachmann (monteur, sanitärinstallateur usw).
- (NL) De keuze van de schoeven en pluggen, evenals de manier van de muur en vallen dus ultsluitend onder de verantwoordelijkheid van diegene die het meubel plaatst.
- (SP) La elección del tipo de los torillos y claviros y el modo de perforar la pared dependen de la naturaleza y de la calidad del muro y por esto dependen de la responsabilidad de la persona quien instala.
- (I) La scelta dei tipi di viti e tasselli, oltre che il sistema di foratura per il fissaggio murale sono da scegliere in funzione della struttura e qualita del muro, e per questo. La responsabilita spetta à chi esegue la posa.
- (P) A escolha do tipos de parafusos e cavilhas assim que o metodo de furar para colocar as fixacoes murais depende da natureza e da qualidade do muro, e de facto, atribuem a unica responsabilidade ao instalator.
- (RUS) Поскольку каждая стена имеет свои особенности, крепеж для установки не поставляется. Специалист по сборке должен подобрать соответствующий тип креплений самостоятельно.



- (F) Tous les raccordements électriques doivent être réalisés selon les réglementations en vigueur par une personne qualifiée
- (GB) All electrical connections must be made in accordance with the latest IEE regulations (BS EN) by a qualified person.
- (D) Alle elektrischen Anschlüsse müssen gemäß den neuesten EDV Bestimmungen von einem Fachmann installiert werden
- (NL) Alle elektrische aansluiten dienen, conform de geldende normen, te worden geïnstalleerd door een erkend installateur
- (SP) Todas las conexiones eléctricas deberán ser realizadas por personal cualificado y siguiendo las regulaciones marcadas por el IEE (Instituto de Ingenieros Eléctricos)
- (I) Elettriche devono essere eseguite da personale qualificato e in conformità alle più recenti norme IEE (Institution of Electrical Engineers)
- (P) Todos os racordamentos eléctricos devem ser realizados segundo as reglementações em vigor por uma pessoa qualificada
- (RUS) **Все электрические соединения должны устанавливаться квалифицированным персоналом и соответствовать последним стандартам IEE (Институт Инженерной Электроники, Великобритания)**

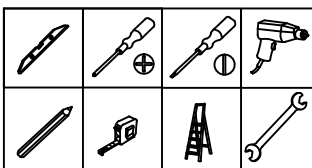
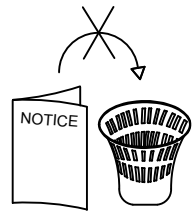
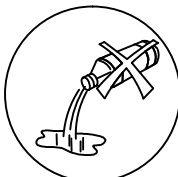

01

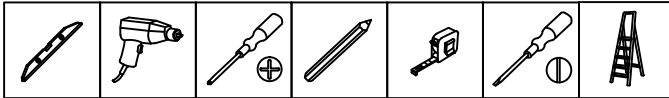
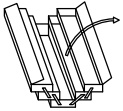
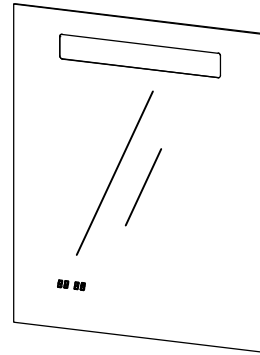

02

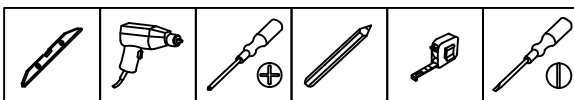
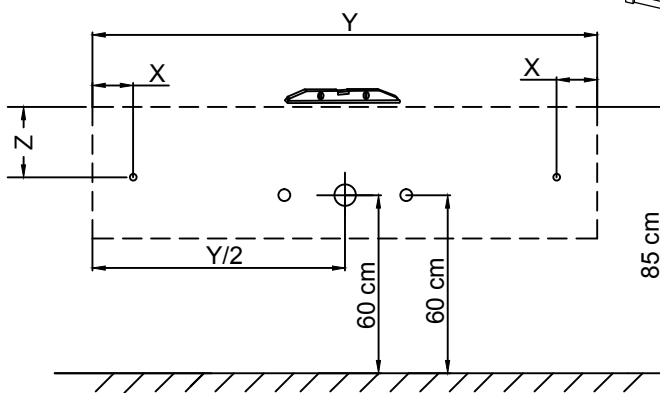
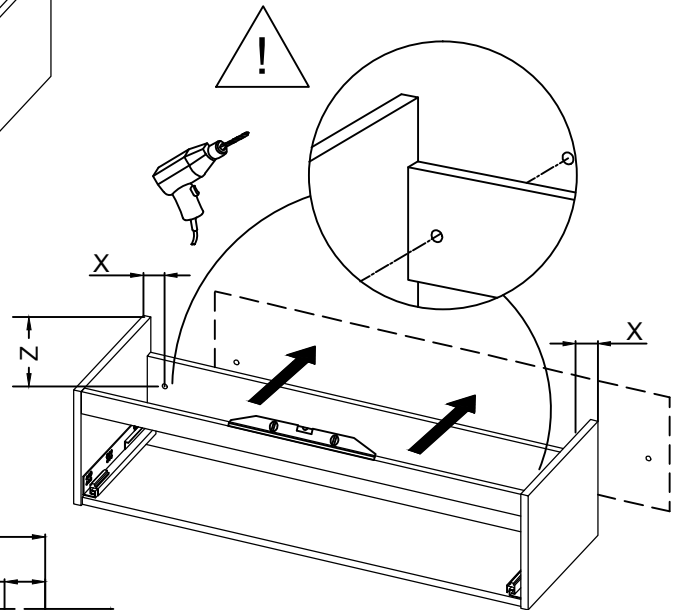
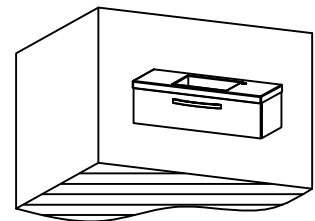
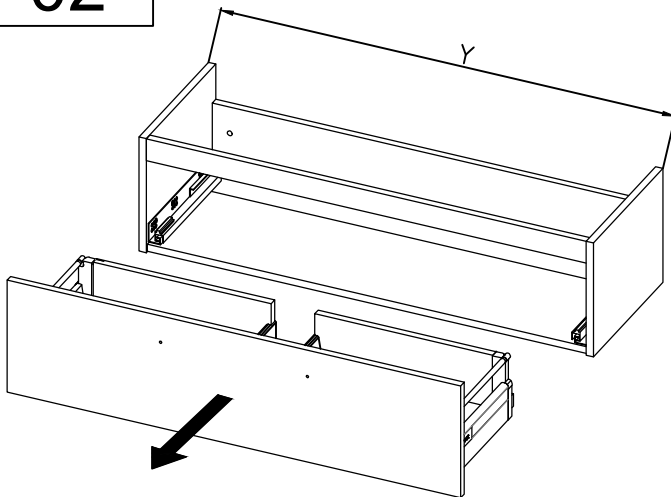

03

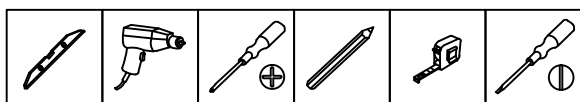
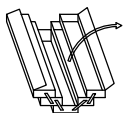
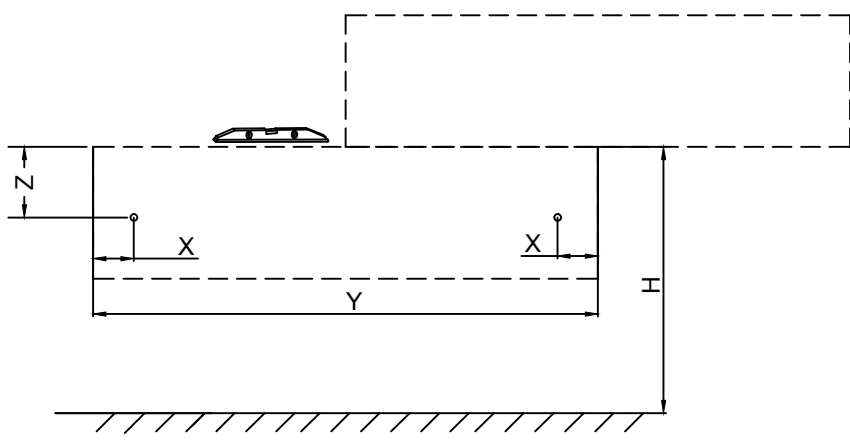
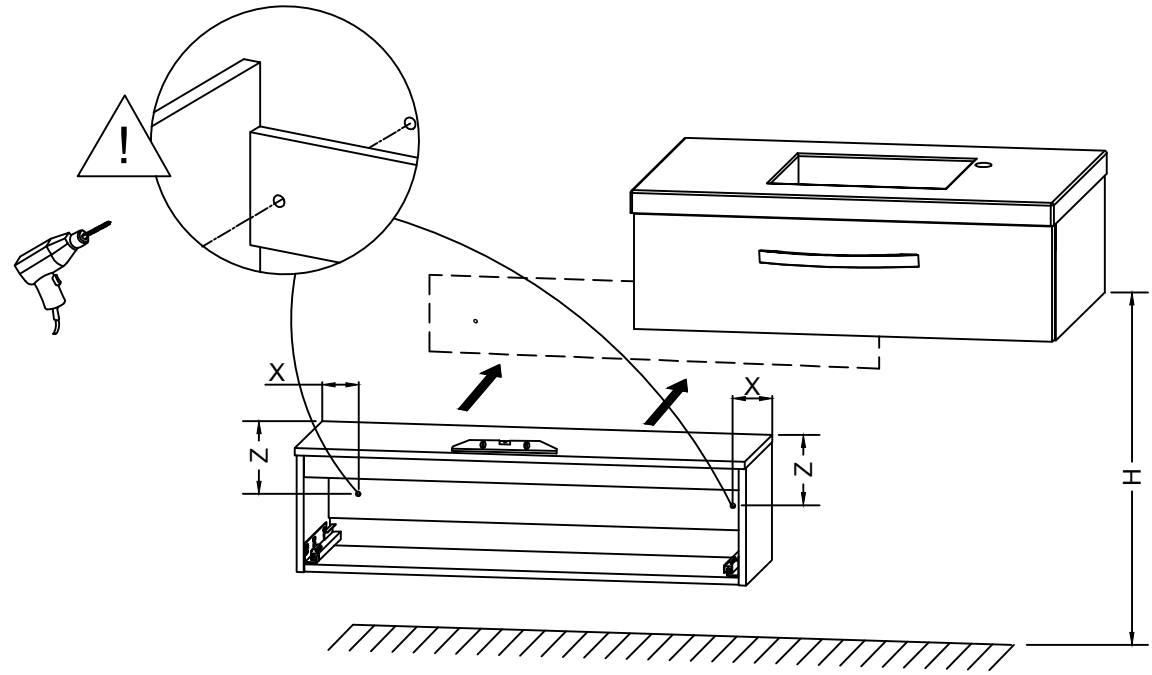
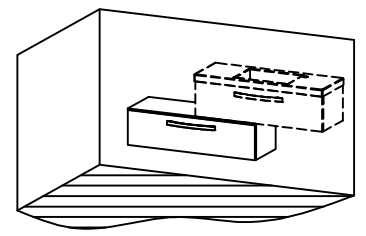
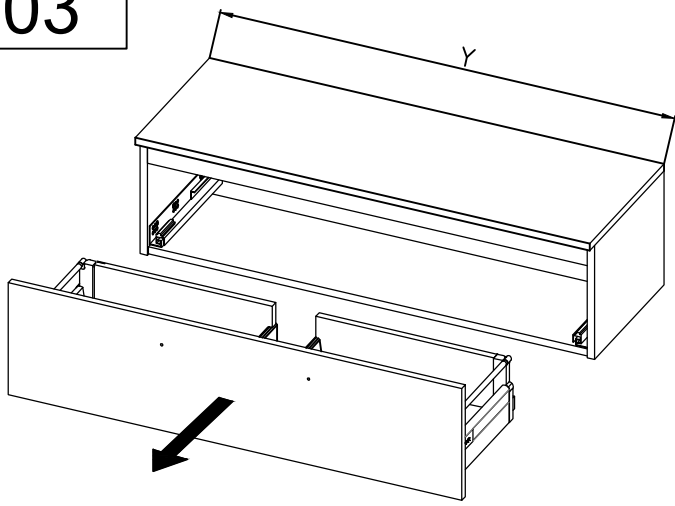

04

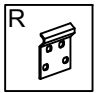
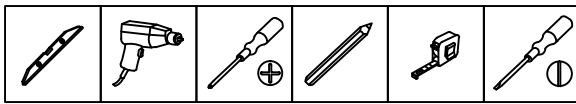
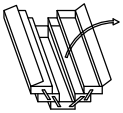
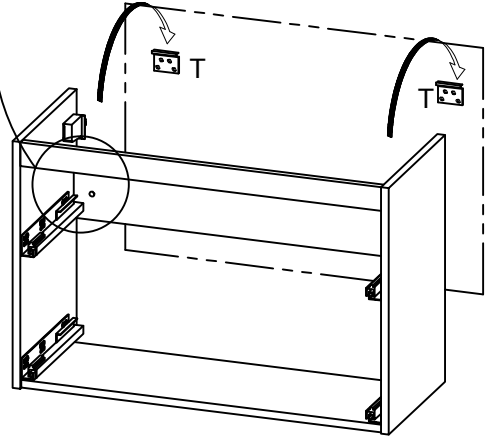
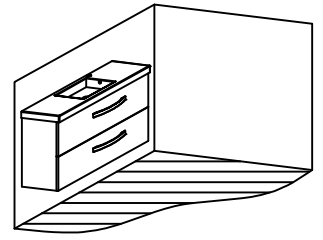
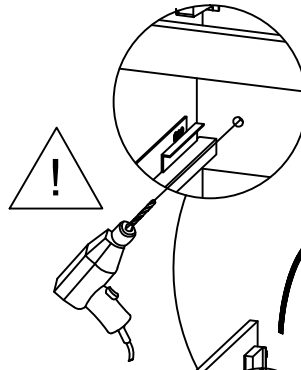
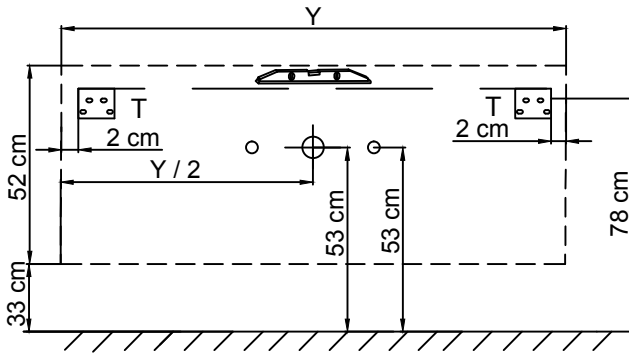
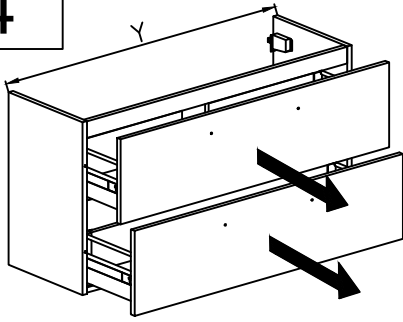

05

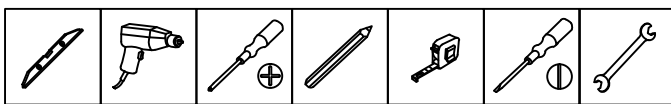
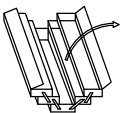
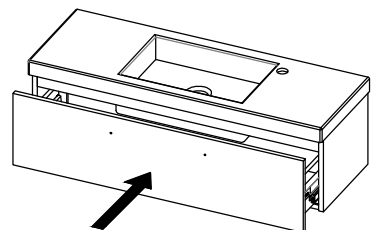
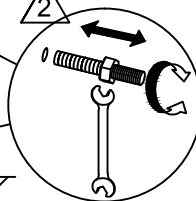
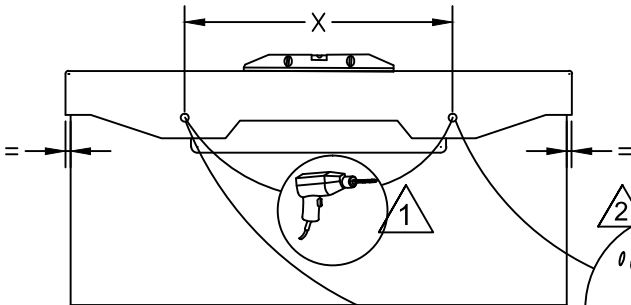
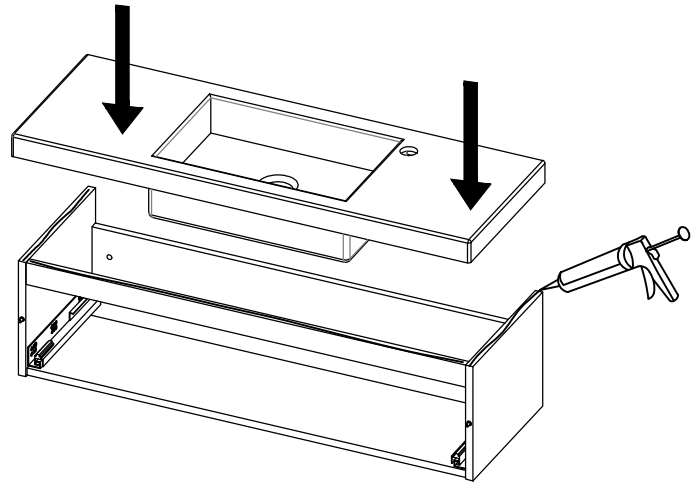
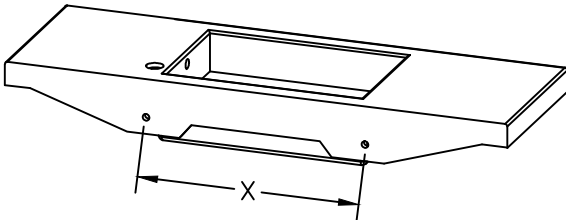

06

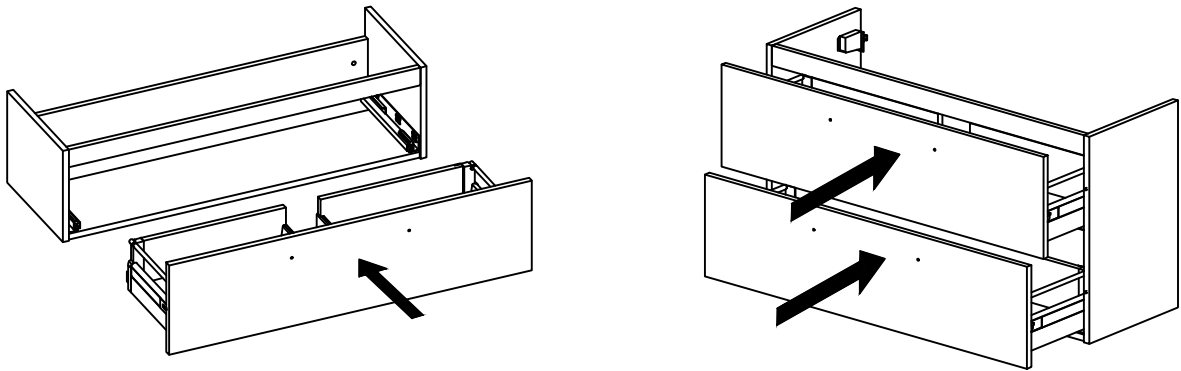

07

